

# ACTUATOR TYPE - E12

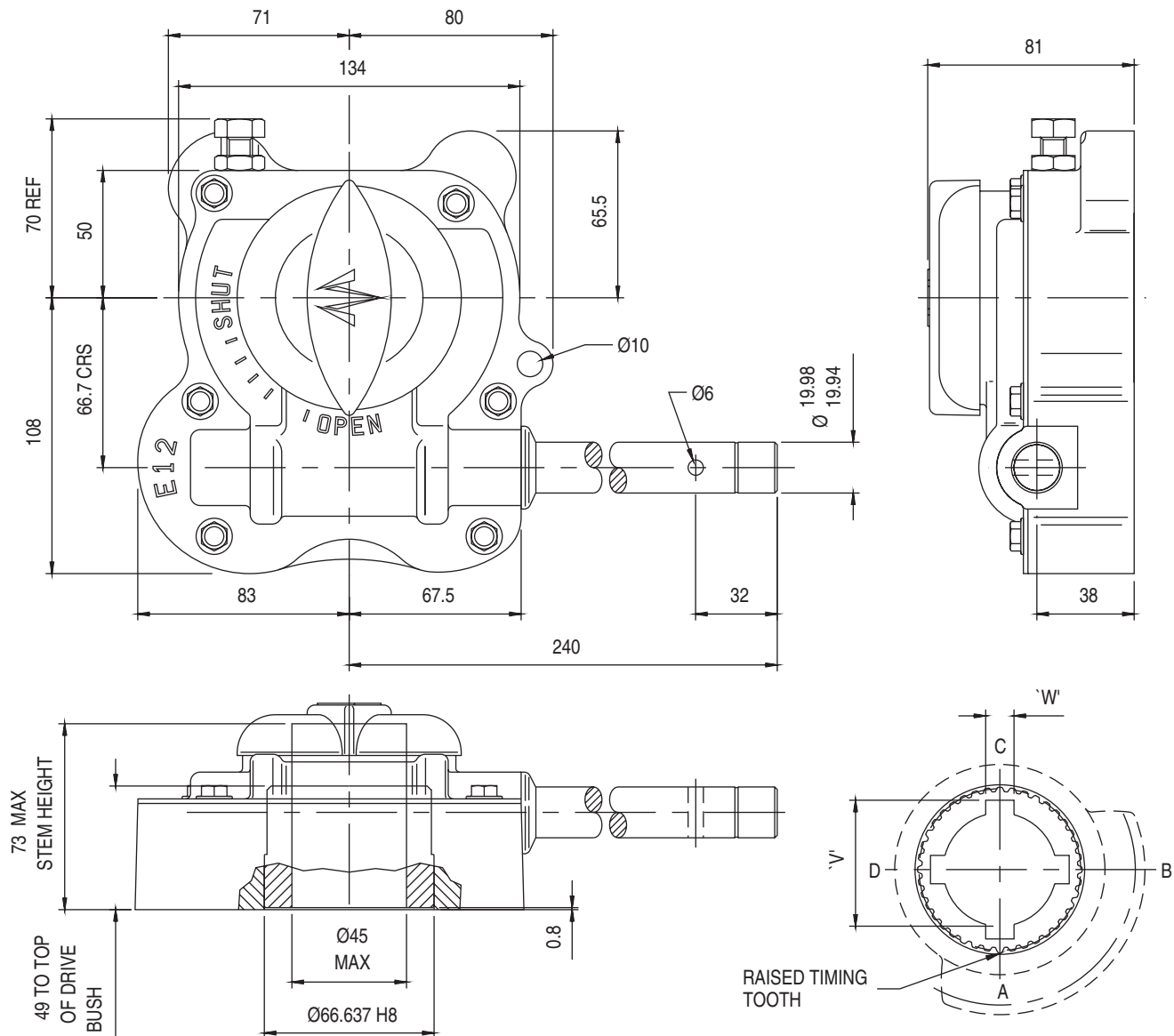

## GENERAL INFORMATION

TRAVEL.....90° +/- 5° AT CLOSED END  
 RATIO.....42:1  
 TURNS TO CLOSE.....10.5

MECHANICAL ADVANTAGE.....8.0 +/- 10%  
 MAXIMUM OUTPUT TORQUE.....1000 Nm  
 MAXIMUM INPUT TORQUE.....125 Nm

MOUNTING HOLE DETAIL: PREFERRED....F10 & F14  
 MAXIMUM.....F14 (4 x M16 ON 140 PCD)  
 MINIMUM.....F10 (4 x M10 ON 102 PCD)

APPROXIMATE WEIGHT.....6.6 Kg (excluding handwheel)

HANDWHEEL DATA	
TYPE	DIA
SR14	350
R18	457

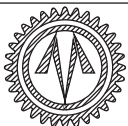

**OPPERMAN MASTERGEAR**

Hambridge Road, Newbury, Berkshire, RG14 5TS. ENGLAND  
 Telephone: (01635) 811500 Telefax: (01635) 811501

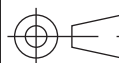

DIMENSIONS  
IN

SCALE

DRAWING  
No.

MM

1:2.5

ME-15407

THIS DRAWING/DESIGN IS THE PROPERTY OF OPPERMAN MASTERGEAR LTD. AND ©  
 MUST NOT BE USED OR COPIED WITHOUT THEIR SPECIFIC WRITTEN CONSENT.

REV. A  
 23FEB98