

# A110 BEVEL GEAR MSS

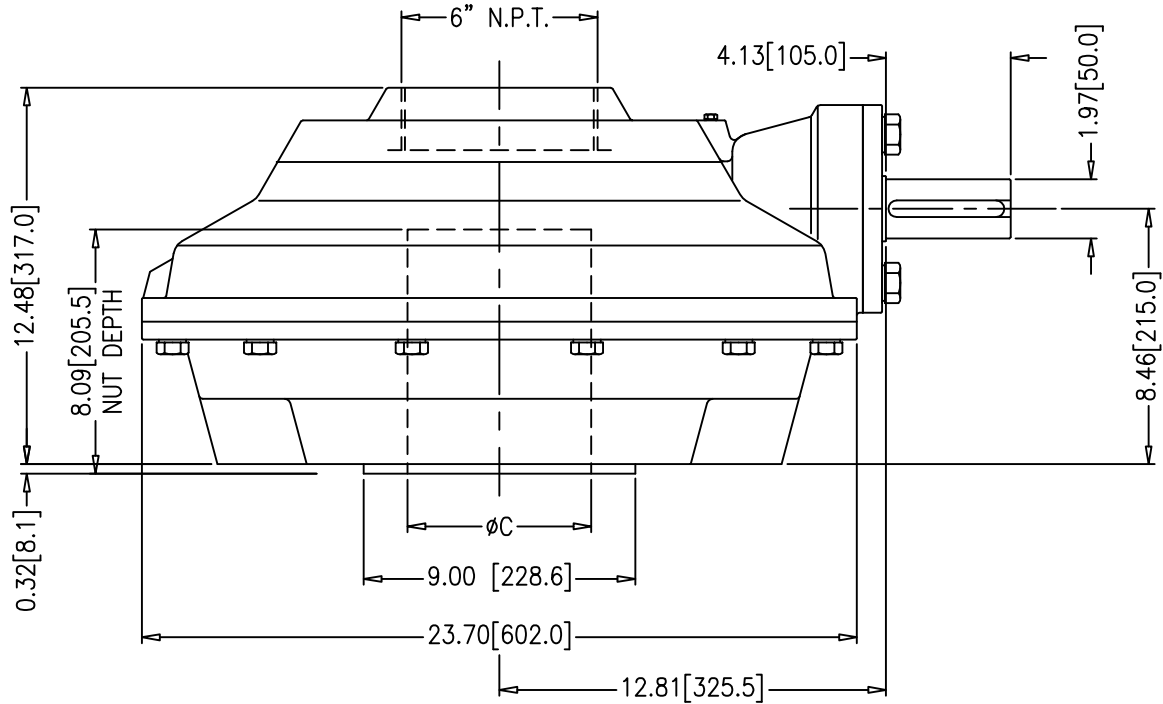

1 1/4-7 TAP~ 8 HOLES  
ON A 16.00[406mm] B.C.D.

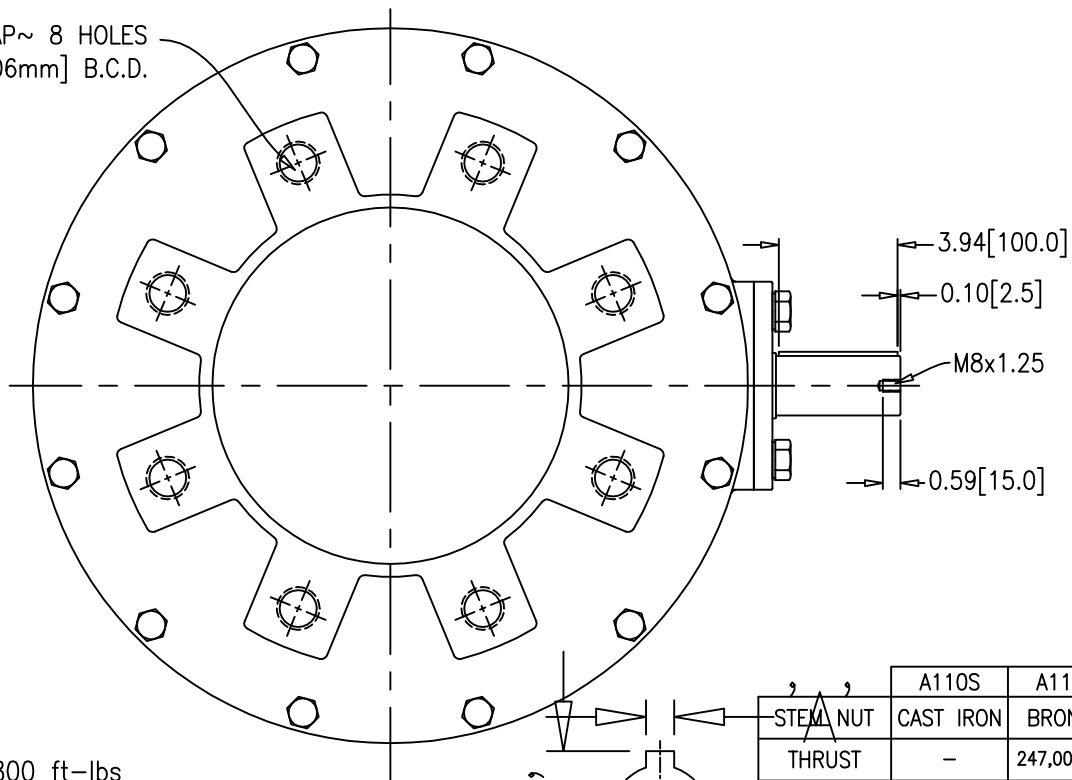

**NOTES:**

1. TORQUE: 11,800 ft-lbs
2. MECHANICAL ADVANTAGE: 4.26
3. RATIO: 5:1
4. DIMENSIONS: IN [MM]

	A110S	A110R
STEM NUT	CAST IRON	BRONZE
THRUST	-	247,000 lbs
'A' MAX	1.97	-
'B' MAX	8.72	-
φ 'C' MAX	8.27	5.51



**MASTERGEAR**  
DIVISION OF REGAL-BELOIT CORPORATION

THIS PRINT IS CONFIDENTIAL AND IS THE PROPERTY OF MASTERGEAR. IT SHALL NOT BE USED, COPIED OR REPRODUCED IN WHOLE OR IN PART NOR SHALL THE CONTENTS BE REVEALED IN ANY MANNER TO ANYONE UNLESS WRITTEN PERMISSION IS OBTAINED FROM MASTERGEAR. ©

DO NOT SCALE  
APPROVED BY  
JRH

DRAWING No.  
A110MSS  
REV. C  
7/17/09