

# ACTUATOR TYPE - MVWD43/TF10TP

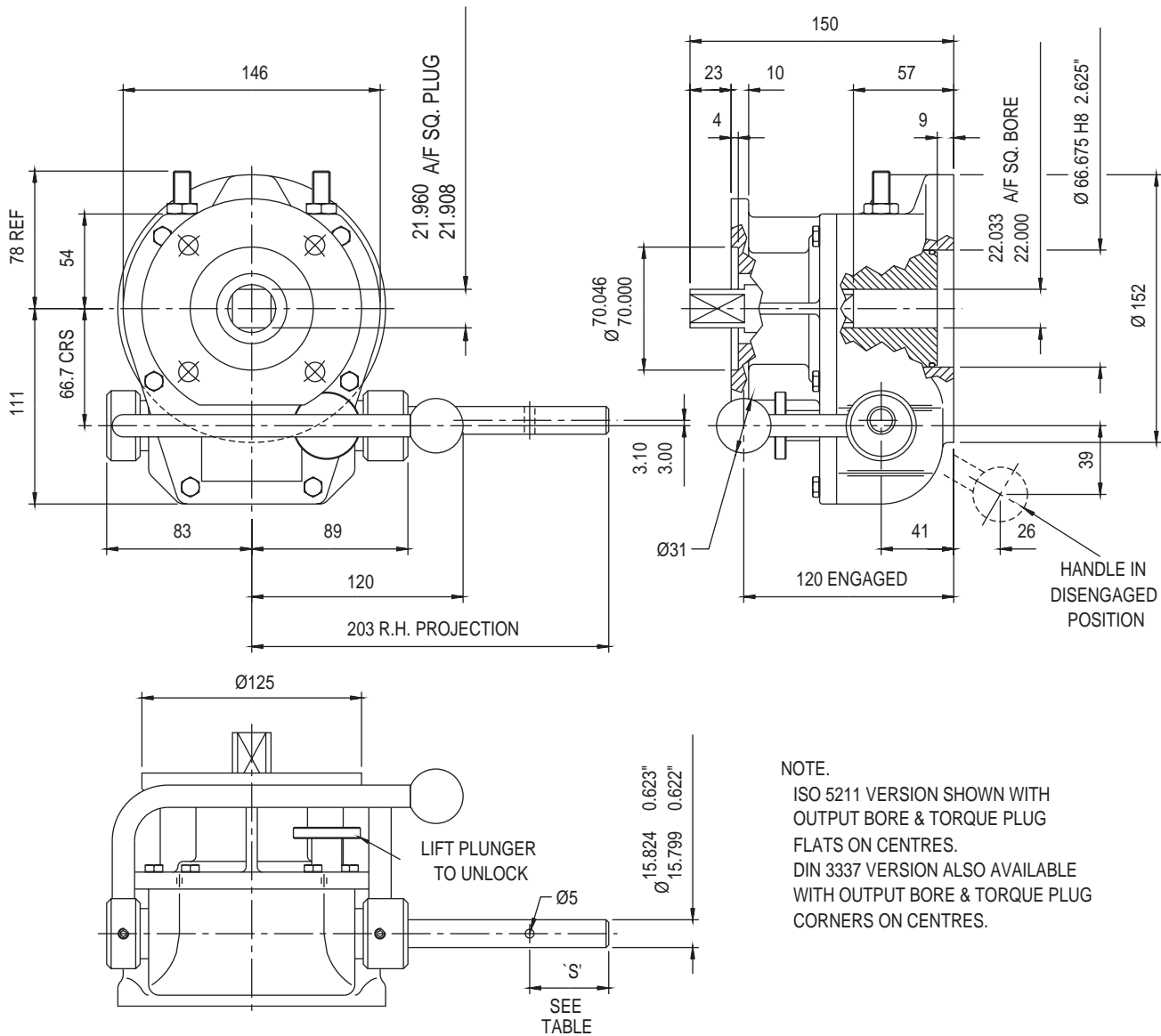

NOTE.  
 ISO 5211 VERSION SHOWN WITH  
 OUTPUT BORE & TORQUE PLUG  
 FLATS ON CENTRES.  
 DIN 3337 VERSION ALSO AVAILABLE  
 WITH OUTPUT BORE & TORQUE PLUG  
 CORNERS ON CENTRES.

TRAVEL.....90° +/- 5° AT BOTH ENDS  
 RATIO.....43:1  
 TURNS TO CLOSE.....10.75

HANDWHEEL DATA		
	HANDWHEEL DIA	'S'
8"	203	25
10"	254	32
12"	305	32

MECHANICAL ADVANTAGE.....11.6 +/- 10%  
 MAXIMUM OUTPUT TORQUE.....678 Nm  
 MAXIMUM INPUT TORQUE.....58.5 Nm

BASE MOUNTING HOLE DETAIL.....F10 (4 x M10 ON 102 PCD)  
 TOP MOUNTING HOLE DETAIL.....4 x Ø11 ON 102 PCD OFF CRS

APPROXIMATE WEIGHT.....12 Kg (excluding handwheel)

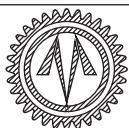

**OPPERMAN MASTERGEAR**

Hambridge Road, Newbury, Berkshire, RG14 5TS. ENGLAND  
 Telephone: (01635) 811500 Telefax: (01635) 811501

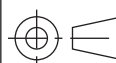

DIMENSIONS IN	SCALE	DRAWING No.
MM INCHES	1:6.5	ME15712

THIS DRAWING/DESIGN IS THE PROPERTY OF OPPERMAN MASTERGEAR LTD. AND  
 MUST NOT BE USED OR COPIED WITHOUT THEIR SPECIFIC WRITTEN CONSENT.