

ACTUATOR TYPE - MCWD54/TF12TP

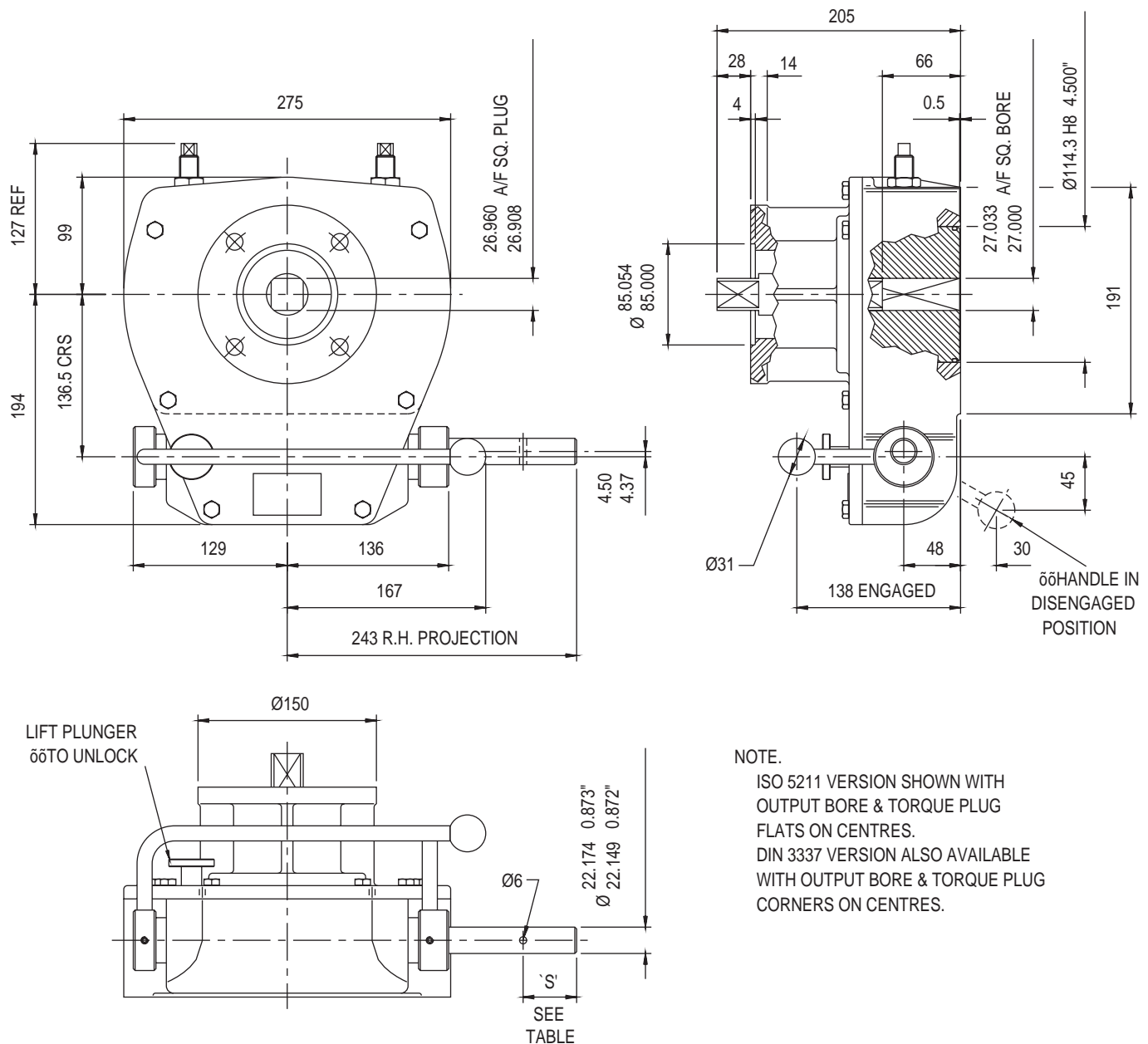

GENERAL INFORMATION

TRAVEL.....90° +/- 5° AT BOTH ENDS
 RATIO.....54:1
 TURNS TO CLOSE.....13.5

MECHANICAL ADVANTAGE.....16.7 +/- 10%
 MAXIMUM OUTPUT TORQUE.....3220 Nm
 MAXIMUM INPUT TORQUE.....192.8 Nm

BASE MOUNTING HOLE DETAIL.....F14 (4 x M16 ON 140 PCD)
 TOP MOUNTING HOLE DETAIL.....4 x Ø14 ON 125 PCD OFF CRS

APPROXIMATE WEIGHT.....39 Kg (excluding handwheel)

HANDWHEEL DATA		
HANDWHEEL DIA		'S'
8"	203	25
10"	254	32
12"	305	32
14"	356	32
18"	457	45
24"	610	45

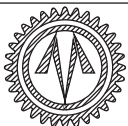

OPPERMAN MASTERGEAR

Hambridge Road, Newbury, Berkshire, RG14 5TS. ENGLAND
 Telephone: (01635) 811500 Telefax: (01635) 811501

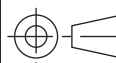

DIMENSIONS
IN

SCALE

DRAWING
No.

MM INCHES

1:5

ME-15731

THIS DRAWING/DESIGN IS THE PROPERTY OF OPPERMAN MASTERGEAR LTD. AND ©
 MUST NOT BE USED OR COPIED WITHOUT THEIR SPECIFIC WRITTEN CONSENT.

REV. C
 25NOV98